

RoHS2.0

REV.	ECN NO.	APPD.
A	ECN230422-004	Alvin Zhang
B	ECN231107-009	Alvin Zhang
C	ECN231226-006	Alvin Zhang

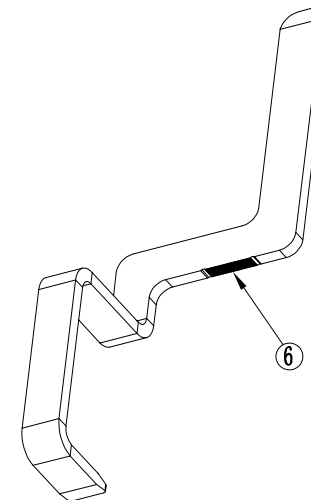
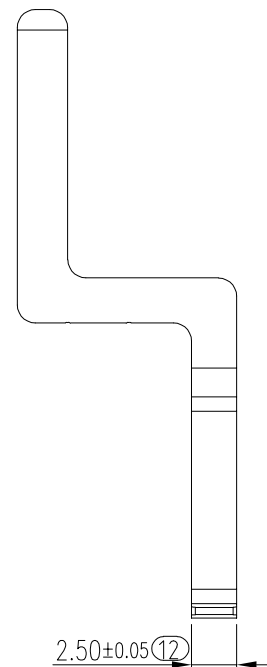
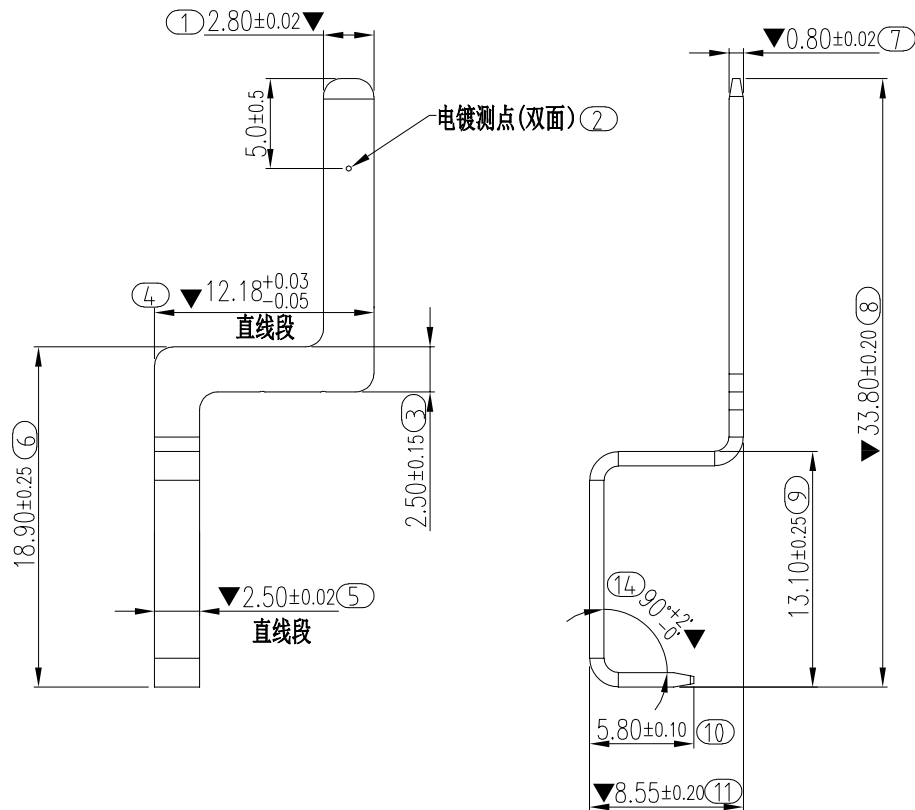

技术要求:

1. 原材料: C1100(T2), T=0.80mm;
2. 表面平整光滑, 允许轻微毛刺; 无锈迹、油污、明显划痕等外观质量问题;
3. 端子可通过72H中性盐雾试验测试(8H测试4H休眠), 允许表面镀层有轻度的破坏所致的斑点和颜色变化, 面积在0.1%-0.25%范围内;
4. "▼"为重要尺寸, 在生产过程中均需检验;

5. 电镀规格:

NI 1-3 μm UNDERPLATING OVERALL;
BRIGHT SILVER 3-5 μm PLATING OVERALL;

⑥. 图示处为产品裁切后露铜区域;

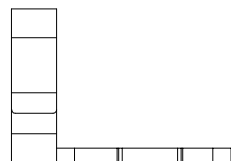

TOLERANCES UNLESS OTHERWISE SPECIFIED		UNITS	mm				
X.± /	X'.± /	MAT'L	COCENTRA® 科信成精密技术 (江苏) 有限公司 COCENTRA PRECISION TECHNOLOGY (JIANGSU) Co. LTD				
.X± /	.X'± /	NA	DWG NAME:	CUSTOMER DRAWING			
.XX± /	.XX'± /	FINISH	TITLE:	电动水泵接插件组件端子2			
THESE DRAWINGS AND SPECIFICATIONS ARE THE PRIOR WRITTEN CONSENT OF COCENTRA PRECISION TECHNOLOGY (JIANGSU) Co. LTD. AND SHALL NOT BE REPRODUCED, COPIED OR USED IN ANY MANNER WITHOUT THE PRIOR WRITTEN CONSENT OF COCENTRA PRECISION TECHNOLOGY (JIANGSU) Co. LTD.		NA	APPD:	David Wang	2023/12/26	PART NO.:	058-00A3-0003
		Q'TY	CKD:	DWG NO.:			307-0000-0433
		NA	DR:	Kevin Lv	2023/12/26	SCALE	SHEET
						N/A	1/1
						REV.	C