

DOCUMENT NAME: PRODUCT SPECIFICATION	SUBJECT: RF I BOARD END CONNECTOR	DOCUMENT NO: SPEC-ANB-1001			
		PAGE	1 OF 11	REV	C

PRODUCT SPECIFICATION

NO.SPEC-ANB-1001

RF I BOARD END CONNECTOR

(Product NO. ANB0200*-12*)

	APPROVED	CHECKED	PREPARED	ISSUED BY :
By	Wesley.Wang	Roy.Duan	Roy.Duan	
Date	2021-04-17	2021-04-17	2021-04-17	

DOCUMENT NAME: PRODUCT SPECIFICATION	SUBJECT: RF I BOARD END CONNECTOR	DOCUMENT NO: SPEC-ANB-1001			
		PAGE	2 OF 11	REV	C

***** REVISION HISTORY *****

Rev.	Date	Revision Page No.	Notes
A	2012-06-05	New Reversion	初次发行
B	2017-07-18	修改参数	更新发行
C	2021-04-17	修改参数	更新发行
D			
E			
F			
G			
H			
J			
K			
L			
M			
N			
P			
Q			
R			
S			
T			
U			
V			
W			
Y			
Z			

DOCUMENT NAME: PRODUCT SPECIFICATION	SUBJECT: RF I BOARD END CONNECTOR	DOCUMENT NO: SPEC-ANB-1001			
		PAGE	3 OF 11	REV	C

1. SCOPE

This product described in this document is a SMT Type Micro Coaxial RF Receptacle, whose part name in our comply is RF REC. It is special for micro strip-to -Coaxial adapter in RF circuit, such as Mobile Phone, Wireless Net, Mini PCI, Bluetooth, PDA, GPS, Electric Measurement Instruments and so on.

2. REQUIREMENT

2.1. PRODUCT DIMENSION

Product shall be intermateable with industry standard product of opposite gender. This connector shall have the dimensions as shown in Drawing .

2.2. PCB/PANEL LAYOUT

The recommended PCB layout is shown in Drawing .

2.3. BILL OF MATERIAL

The bill of material and product number of Connectors are described in Drawing .

2.4. MECHANICAL & ELECTRICAL CHARACTERISTIC

The connector shall have the mechanical and electrical performance as described in **Table I**.

2.5. PACKAGING

Parts shall be packaged according to requirements specified in purchase order for safe delivery. Connector container and the packing specification are shown in Drawing .

2.6. HARMFUL MATERIAL CONTROL

Harmful material controls please follow the **Doc. No. QW-QA-10**.

3. Part No., construction, material and finish

- (1) Part No. Receptacle: ANB0200*-12* Plug: ANCZ1***-***,
- (2) Construction, material and finish of the connector are covered as each drawing.
- (3) The plug side application cable requirements

Characteristic impedance: $50 \pm 2 \Omega$ by TDR method

Nominal capacitance (Reference value) : 98 pF/m

Conductor resistance of inner conductor at 293K (20°C) (Reference value) : 1400 ohm/km

Insulation resistance: 1000 mega-ohm.km MIN.

Dielectric withstand voltage: no breakdown at AC1000V for 1 minutes.

DOCUMENT NAME: PRODUCT SPECIFICATION	SUBJECT: RF I BOARD END CONNECTOR	DOCUMENT NO: SPEC-ANB-1001			
		PAGE	4 OF 11	REV	C

4. PRODUCT PICTURE

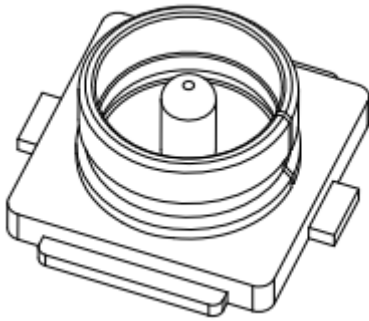

5. Ratings

Rated voltage	AC60Vrms
Nominal characteristic Impedance	50 ohm
Frequency	DC~8GHz
VSWR	Plug: 0.1~3GHZ 1.3Max. 3~6GHZ 1.5Max. 6~8GHZ 1.6Max. Receptacle: 0.1~3GHZ 1.3Max. 3~6GHZ 1.4Max. 6~8GHZ 1.5Max.
Service Temperature	233K~363K(-40°C~90°C)
Storage condition	Tempereature:248K~333K(-25°C~+60°C) Humidity:85% Max. (No condensation)

6. Test and Performance

Test Condition

Unless otherwise specified, all tests and measurements shall be performed under the following condition in accordance with MIL-STD-202G.

Temperature -----288K~308K(15°C~35°C)

Humidity -----45~75%R.H.

DOCUMENT NAME: PRODUCT SPECIFICATION	SUBJECT: RF I BOARD END CONNECTOR	DOCUMENT NO: SPEC-ANB-1001			
		PAGE	5 OF 11	REV	C

6-1 Electrical Performance

NO	Item	Test conditions	Specifications
1	Contact resistance	<p>Subject the receptacle connector to the test board and mate the plug connector together, then measure the contact resistance as shown in Fig.1 by the four terminal method. Apply the low level condition in accordance with MIL-STD-202G, Method307.</p> <p>Open circuit voltage: 20mV Max. Circuit current :10mA Max. (DC or AC1kHz)</p> <p>Contact resistance of Inner contact=A-B Contact resistance of Ground contact=D-C</p>	<p>Contact resistance of inner contact Initial: 20 mΩ Max. After testing: 25 mΩ Max.</p> <p>Contact resistance of ground contact Initial: 10 mΩ Max. After testing: 15 mΩ Max.</p>
<p>Fig. 1</p>			
2.	Insulation Resistance	<p>Mate the receptacle and plug connector together, and then apply DC 100V between the inner contact and the ground contact in accordance with MIL-STD-202G, Method 302.</p>	<p>Initial :500MΩ Min. After testing :100 MΩ Min.</p>

DOCUMENT NAME: PRODUCT SPECIFICATION	SUBJECT: RF I BOARD END CONNECTOR	DOCUMENT NO: SPEC-ANB-1001		
		PAGE	6 OF 11	REV C

NO	Item	Test conditions	Specifications
3	Dielectric Withstanding Voltage	Mate the receptacle and plug connector together, and then apply AC 200V rms between the inner contact and the ground contact for a minute in accordance with MIL-STD-202G, Method 301.	No creeping discharge, flashover, no insulator breakdown shall occur.
4.	VSWR	Measure the VSWR as shown in Fig. 2 by the network analyzer. Frequency: 100M~8GHz	1.3Max. at 0.1~3GHz 1.4Max. at 3~6GHz 1.5Max. at 6~8GHz

Fig. 2

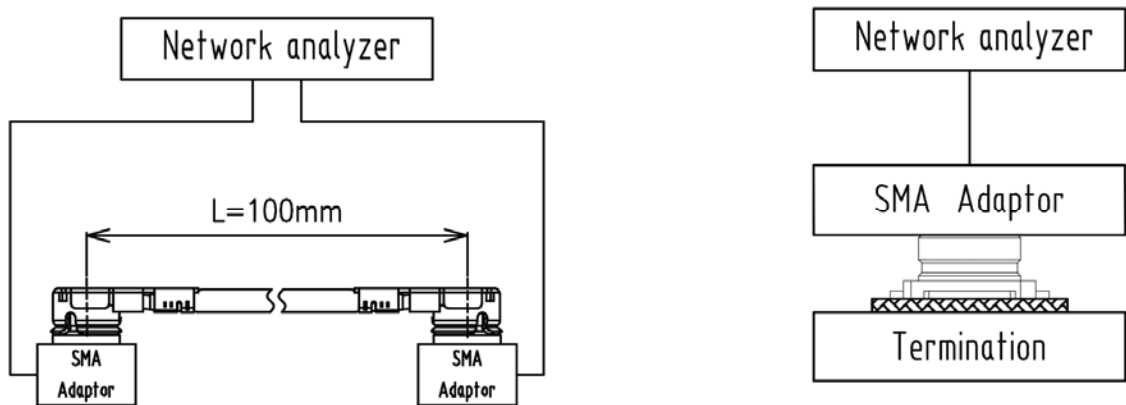

DOCUMENT NAME: PRODUCT SPECIFICATION	SUBJECT: RF I BOARD END CONNECTOR	DOCUMENT NO: SPEC-ANB-1001			
		PAGE	7 OF 11	REV	C

6-2 Mechanical Performance

NO	Item	Test conditions	Specifications
1	Mating Force And Un-mating Force	Solder the receptacle connector to the test board, then place the board and plug on push-on/pull-off machine, measure of initial and mating/un-mating 30 cycles at a speed 25±3mm/min. along the mating axis.	Mating Initial : 30 N Max. 30cycles: 30 N Max. Total un-mating force Initial :5N Min. After 30 cycles:3N Min Un-mating force of inner contact Initial :0.15N Min. After 30 cycles:0.10N Min.
2	Receptacle shearing strength	Solder the receptacle connector to the test board, Push the receptacle connector from each directions as Shown in Fig.3 Measure the strength when the connector is broken.	20N Min.
<p>Fig.3</p> <p>Direction2 Direction3 Direction1 Direction4 Block gage 0.15mm Receptacle connector PCB</p> <p>图 4. 半田剥離強度 (Fig.4 Receptacle shearing strength)</p>			
3	Durability	Mate and un-mate the receptacle connector(soldered to the test board) and plug connector 30 cycles at speed 25±3 mm/minutes along the mating by the push-on / pull-off machine.	[Appearance] No abnormality [Contact Resistance] Shall meet 6.1.1

DOCUMENT NAME: PRODUCT SPECIFICATION	SUBJECT: RF I BOARD END CONNECTOR	DOCUMENT NO: SPEC-ANB-1001			
		PAGE	8 OF 11	REV	C

Item	Test conditions	Specifications
Contact resistance with force on the cable	Apply force on the cable as shown in Fig.4 During the testing, run 100mA DC to check electrical discontinuity.	[Appearance] Looseness between the parts, chipping, breakage or other abnormality shall not occur. [Electrical discontinuity] No electrical discontinuity grater than 1µs shall occur. [Contact Resistance] Shall meet 6.1.1

Fig.4

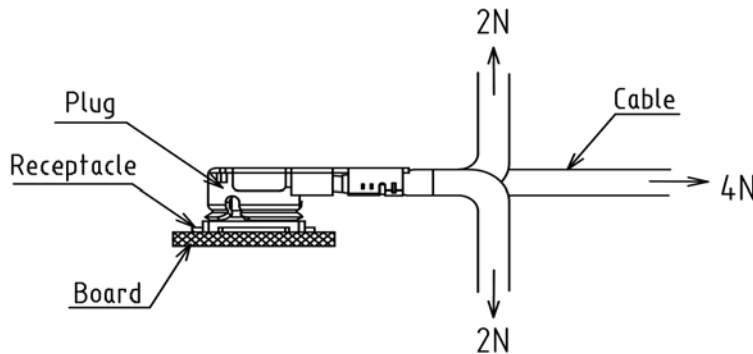

Vibration	Apply the following vibration to the mating connector. During the testing, run 100mA DC to check electrical discontinuity. Frequency: 10Hz →100 Hz →10Hz/approx 20 minutes. Half amplitude, Peak value of acceleration : 1.5mm or 59m/s ² (6G) Directions, cycle: 3 mutually perpendicular direction,3 cycles about each direction.	[Appearance] Looseness between the parts, chipping, breakage or other abnormality shall not occur. [Electrical discontinuity] No electrical discontinuity grater than 1µs shall occur. [Contact Resistance] Shall meet 6.1.1
Shock	Apply the following vibration to the mating connector. During the testing, run 100mA DC to check electrical discontinuity. Peak value of acceleration: 735 m/s ² (75G) Duration :11msec Wave Form :half sinusoidal Direction, cycle :6 mutually perpendicular direction, 3cycle about each direction.	[Appearance] Looseness between the parts, chipping, breakage or other abnormality shall not occur. [Electrical discontinuity] No electrical discontinuity grater than 1µs shall occur. [Contact Resistance] Shall meet 6.1.1

DOCUMENT NAME: PRODUCT SPECIFICATION	SUBJECT: RF I BOARD END CONNECTOR	DOCUMENT NO: SPEC-ANB-1001			
		PAGE	9 OF 11	REV	C

6-3 Environmental Performance

NO	Item	Test conditions	Specifications
1	Thermal Shock	Apply the following environment to the mating connector. Temperature, duration in accordance with MIL-STD-202G, Method 107G, Condition A. Temperature : 233K (-40°C)/ 30 minutes →278~308K(5~35°C)/5 minutes Max. →363K(90°C)/30 minutes →278~308K(5~35°C)/5 minutes Max. No. of cycles : 5 cycles	[Appearance] Looseness between the parts, chipping, breakage or other abnormality shall not occur. [Contact Resistance] Shall meet 6.1.1 [Insulation Resistance] Shall meet 6.1.2
2	Humidity (Steady State)	Apply the following environment to the mating connector in accordance with MIL-STD-202G, Method 103, Condition B. Temperature : 313±2K (40±2°C) Humidity : 90~95%RH Duration : 96 hours	[Appearance] Looseness between the parts, chipping, breakage or other abnormality shall not occur. [Contact Resistance] Shall meet 6.1.1 [Insulation Resistance] Shall meet 6.1.2.
3	Salt Water Spray	Apply the following environment to the mating connector in accordance with MIL-STD-202G, Method 101E, Condition B. Temperature : 308±2K (35±2°C) Salt water density : 5±1%(by weight) Duration : 48 hours	[Appearance] No abnormality adversely affecting the performance shall occur.
4	High Temperature Life	Apply the following environment to the mating connector Temperature : 363±2K (90±2°C) Duration : 96 hours	[Appearance] Looseness between the parts, chipping, breakage or other abnormality shall not occur. [Contact Resistance] Shall meet 6.1.1

DOCUMENT NAME: PRODUCT SPECIFICATION	SUBJECT: RF I BOARD END CONNECTOR	DOCUMENT NO: SPEC-ANB-1001			
		PAGE	10 OF 11	REV	C

6-4 Soldering

NO	Item	Test conditions	Specifications
1	Solder ability	Dip the solder tine of the contacts in the solder bath at 518±5K(245±5°C) for 5±0.5seconds after immersing the tine in the flux of RMA type for 5 to 10 seconds in accordance with MIL-STD-202,Method 208.	More than 95%of the dipped surface shall be evenly wet .
2	Soldering Heat Resistance	Put on the receptacle connector to PCB , apply the heat 2 cycles as shown in Fig.5	[Appearance] No abnormality Adversely Affecting the performance shall occur.

Fig.5

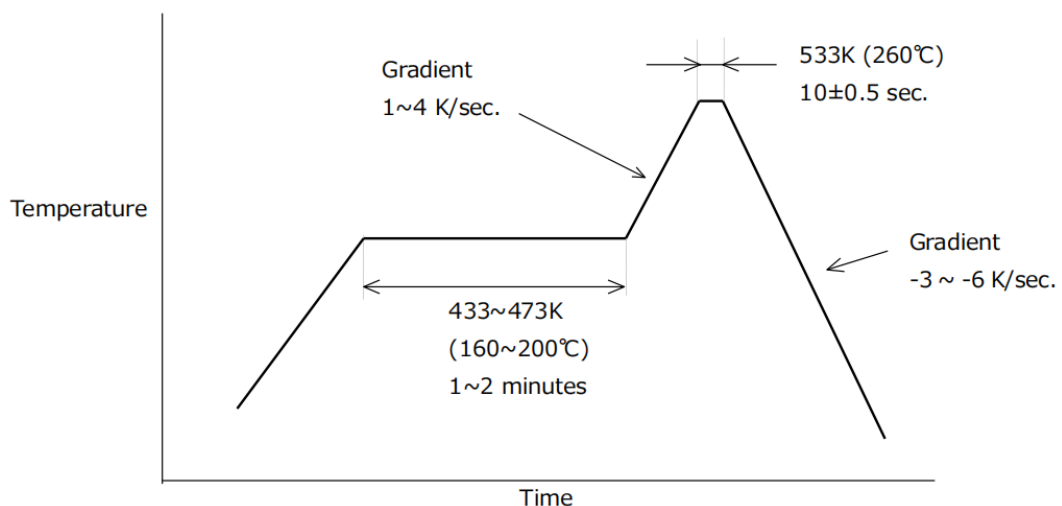

DOCUMENT NAME: PRODUCT SPECIFICATION	SUBJECT: RF I BOARD END CONNECTOR	DOCUMENT NO: SPEC-ANB-1001			
		PAGE	11 OF 11	REV	C

Table II: Test Sequence and Sample Quantity

Test: Measurement or Examination	A	B	C	D	E	F	G	H	I	J	K	L	M
1.Contact Resistance				1,3	1,3	1,3	1,3	1,5	1,5	1,3	1,3	1,3	
2.Insulation Resistance								2,6	2,6				
3.Dielectric Withstanding Voltage								3,7	3,7				
4.VSWR	1												
5.Un-mating force		1											
6.Crimp strength			1										
7.Durability				2									
8.Contact resistance with force on the cable					2								
9.Vibration						2							
10.Shock							2						
11. Thermal Shock								4					
12. Humidity									4				
13. Salt Water Spray										2			
14. High Temperature Life											2		
15. Solder ability												2	
16.Soldering Heat Resistance													1
Sample QTY.	10	10	10	10	10	10	10	10	10	10	10	10	10